

GENERIC SPECIFICATION

RN - CLOSURE

NWC Network Cable Co., Ltd

2F TaeKwng Industrial Building, 191-1 Anyand-dong, Manan-gu, Anyang city Kyung-gi, Korea 430-017
Tel. +82 (0)31 464 3777 Fax. +82 (0)31 464 3797
www.networkcable.co.kr info@networkcable.co.kr

■ GENERAL

The splice closures can be used in underground, aerial, building entrance, Central Office Vault and pedestal application.

■ SCOPE

This specification covers the minimum standards and requirements for the installation, properties, testing and packing of splice closures to be used on optical fiber cables in the telecommunication network.

This specification describes the performance and material testing methods, and the quality assurance provisions for the closures.

■ PRODUCT DESCRIPTION

The closure consists of outer cases, end caps, trays and inner kits. The splice closures have two cable entrance ports on each end.

The outer cases consists of the upper and lower housing and constructed of highly chemical resistant material and attached a pressure valve on the upper housing.

The trays are able to accommodate 24 individual fiber fusion or 12 individual fiber mechanical splices.

■ REQUIREMENTS

The upper and the lower housing of closure shall be manufactured from a material.

The metal parts of closures shall be resistant to corrosion.

The product components shall withstand storage at temperatures of -40 to 85°C.

The components of the closures shall be free of defect which would adversely affect product performance.

The splice closures can be installed at temperatures -40 to 85°C.

The splice closures shall allow the accommodation of the fibers with a nominal bending radius of 30mm.

The kits shall contain all the necessary components for a complete installation.

■ MATERIALS

■ GENERAL

Optical fiber splice closures are mostly deployed in severe environments and should be durable within the expected lifetime of 20 years. This section specifies the optical fiber splice closure and its material requirements.

Materials used for optical splice closure system is compatible with all cable components and splicing materials.

□ External plastic materials

External plastic materials are colored black and are resistant to chemical.

External plastic materials are ultra violet resistant.

□ Metallic materials

All external metal components are stainless steel or metal with equivalent corrosion resistance

The metallic closure materials are not capable of inducing significant galvanic corrosion effects when in contact with other metals likely to be present in the closure's environment.

All internal metal components are suitably protected against corrosion.

□ Internal plastic materials

The Internal components of optical fiber splice closure are made of high quality of plastic resin.

□ Material Toxicity

The components of optical fiber splice closure and its accessories don't contain any hazardous or toxic materials.

□ Performance Verification

Routine inspection tests are performed for performance verification is complied to generic requirements for fiber optic splice closure based on the Telcordia Specifications.

FUNCTIONAL REQUIREMENTS

Test Item	Test Methods and conditions	Requirements
Appearance		No defects which would adversely affect product performance.
Tightness	<ul style="list-style-type: none"> - Internal pressure: 6psi - Test temperature: 23±3 °C - Test time : 15 minutes 	Tightness
Residual loss	<ul style="list-style-type: none"> - Source wavelength : 1550nm 	<0.1dB per incoming fiber
Fiber Organization	<ul style="list-style-type: none"> - Source wavelength : 1550nm 	<0.1dB per incoming fiber
Vibration	<ul style="list-style-type: none"> - Test pressure : 6psi - Vibration:(5~55Hz, 1min./cycle) - Amplitude : 1mm - Test time : 2 hrs 	Tightness <1psi <0.1dB per incoming fiber
Axial Tension	<ul style="list-style-type: none"> - Source wavelength : 1550nm - Load/Cable: D/45x1000N - Test pressure : 6psi - Test time : 8 hrs 	Tightness <1psi <0.1dB per incoming fiber
Torsion	<ul style="list-style-type: none"> - Test pressure : 6psi - Test temperature: -20±2/ 40±2 °C - Torque : 90°→180°→ 90° /2cycle - Torque application : D x 10mm from end of cable port 	Tightness <1psi
Flexure	<ul style="list-style-type: none"> - Test pressure : 6psi - Attached to the cable : 10kg - Bending axis : 90°(3 rotation) - Test time : 15 minutes 	Tightness <1psi
Impact	<ul style="list-style-type: none"> - Test pressure : 6psi - Test temperature: -20±2 °C / 2 hrs - Impact tool : 2.4Kg/d(2.54cm) - Drop height : 1m - Number of impacts : 1 	Tightness <1psi No Cracking
Static Load	<ul style="list-style-type: none"> - Test pressure : 6psi 	Tightness <1psi

Test Item	Test Methods and conditions	Requirements
	<ul style="list-style-type: none"> - Test temperature: 40±2 °C/ 2 hrs - Load: 1000N/5cm² - Test time : 15 minutes 	No Cracking
Handling Test	<ul style="list-style-type: none"> - Drop height : 76cm - Position angle : 60° 	Tightness <1psi No Cracking
Environment Temperature Cycling	<ul style="list-style-type: none"> - Source wavelength : 1550nm - Temperature condition : -30±2 °C ~ 60±2 °C Dwell time : 1 hrs Transition time : 1 hrs Cycle duration : 8 hrs - Number of cycles : 20 - Succession test : Tightness 	Tightness <1psi <0.1dB per incoming fiber
Chemical Resistance	<ul style="list-style-type: none"> - Test pressure : 6psi - Chemical liquid : pH2 HCl, pH12 NaOH, 10%, IGEPAL. - Test time : each 120 hrs 	Tightness <1psi No visible corrosion. No Cracking
Water Immersion test	<ul style="list-style-type: none"> - Depth of water : 1.5m - Test time : 20 days 	Tightness
Dielectric Test	<ul style="list-style-type: none"> - 10kV DC power - Test time : 1 min 	No damage or crack
UV Resistance Test	<ul style="list-style-type: none"> - Xenon lamp of wavelength between 300 and 700nm - UV radiation of 390w/m²±10% - Test time : 500 hrs 	Tensile strength < 25%
Re-entry	<ul style="list-style-type: none"> - Sample after cycling : Open, add single cable 	Tightness

■ TEST PROCEDURES

□ Installed Products Test Procedures

Test samples shall be equipped with one organizer trays with one cables installed in outlet ports. For samples requiring optical testing, a minimum of two fibers shall be spliced inside the closure.

All installations shall be performed according to the supplier's standard installation instructions and at room temperature, unless otherwise stated.

For pressure access, a valve shall be installed in the upper part of closure.

Testing is at room temperature unless otherwise specified.

When tests are specified at temperatures other than ambient, the samples shall be preconditioned for a period of 4 hours at those temperatures.

□ **Visual Examination**

The closure and components shall be inspected for flaws, defects, pinholes, cracks or inclusions visible to the naked eye.

□ **Tightness Test**

The tightness of installed closures shall be checked by pressuring to 6psi for a period of 15 minutes while immersed in water at room temperature.

A sample shall be considered tight if there is no continuous stream of air bubbles escaping from it.

□ **Residual Loss**

This is defined as a measured attenuation which is exhibited by stable transmission measurements taken before and after a test. It shall be measured using an optical source and a detector operating at 1550nm.

□ **Fiber Organization**

The effect of the use of the organizer shall be determined by measuring the signal loss using an optical source and a detector operating at 1550nm.

□ **Vibration Test**

The closure shall be mounted on a vibration bank and shall be displaced with a frequency of up to 55 Hz from 5 Hz and amplitude of 1mm during 2 minute.

After 2 hours, specimens shall be subjected to the tightness test described in Section 6. Residual loss shall also be determined per Section 6.

□ **Axial Tension Test**

The closure assembly shall be clamped, and a force shall be applied to each the extending cables for a period of eight hours. The force shall be calculated according to the equation: $D \text{ (cable outer diameter)}/45 \times 1000\text{N}$, with a

maximum of 1000 N. During the test of the closure shall be pressurized internally to 6 psi. After completion, specimens shall be subjected to the tightness test described in Section 6.

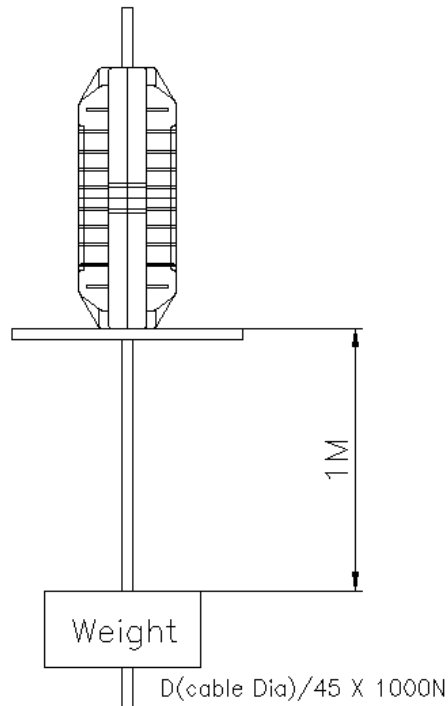

The test shall be repeated for the entire assembly with a load of 1000N being evenly distributed over the cables and closure for eight hours, again followed by the tightness test.

□ Torsion Test

Test samples shall be pressurized internally to 6 psi. Each extending cable shall in turn be clamped rigidly at a distance $D(\text{cable outer dia.})/45 \times 10\text{mm}$ from the entrance port.

The closure shall be axially rotated through 90° and retained to its 180° position and the procedure repeated in the opposite direction. The torque applied shall not exceed 50Nm.

After two cycles per cable, specimens shall be subjected to the tightness test described in Section 6.

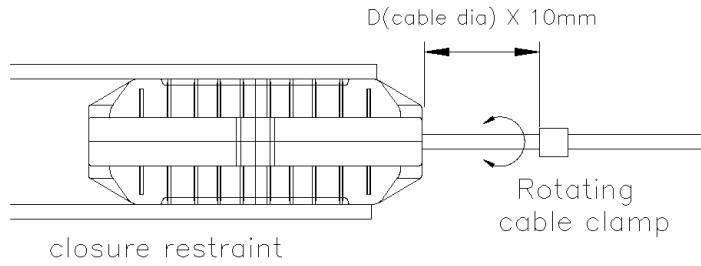

□ **Flexure Test**

The closure shall be clamped on a smooth, flat, horizontal surface. Cables shall be clamped at 100cm from the end of the entrance port then bent 90° and the procedure repeated seven rotation in the opposite direction.

Each bending operation shall be held for 15 minutes. The procedure shall be pressurized to 6 psi for the duration to the test.

After the test, samples shall be subjected to the tightness test described in Section 6.

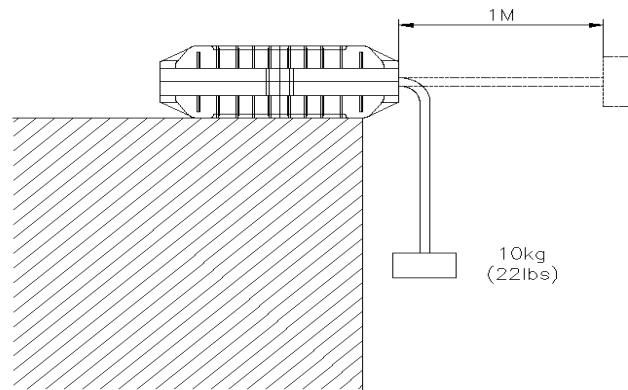

□ **Impact**

Testing shall be operated after storage at $-20\pm 2^{\circ}\text{C}$ during the 2 hours. A sample shall be placed on a smooth, flat, horizontal surface with its longitudinal axis paralleled to it.

A steel ball weighting 2.4kg shall be suspended at a height of 1 m above the

center of the test specimen. The weight shall be allowed to fall under gravity within 30 seconds of preconditioning.

For the duration of the test samples shall be internally pressurized to 6 psi.

After visual inspection with the naked eye, samples shall be subjected to the tightness test described in Section 6.

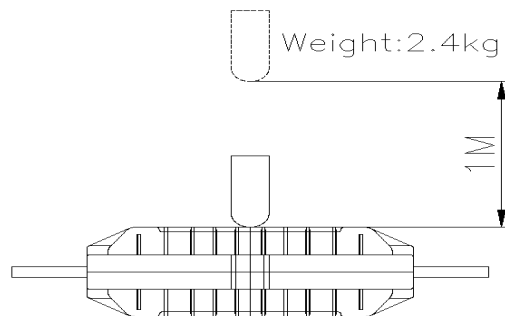

□ Static Load Test

Testing shall be operated after storage at $40\pm 2^{\circ}\text{C}$ during the 2 hours.

A static load of 1000N shall be placed on the closure using a circular compression dia of 5 cm² surface area. The load shall be applied for 15 minutes within 30 seconds of preconditioning. Sample shall be pressurized during the test with an internal pressure of 6 psi.

After completing the test, sample shall be examined with the naked eye and then be subjected to the tightness test described in Section 6.

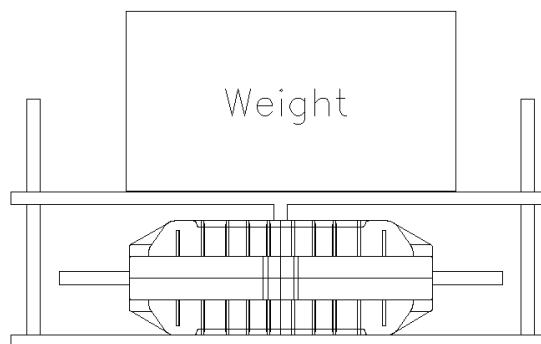

□ Handling Test

The test assembly shall be as shown in the following diagram.

Cable clamping shall allow cable rotation but shall restrict sideways or longitudinal movement.

The sample shall be positioned as shown in the diagram so that it touches a concrete floor at an angle of 60°. It shall then be lifted to a height of 76cm and allowed to fall back to the floor.

Subsequently it shall be examined for cracks with the naked eye, then to the tightness test described in Section 6.

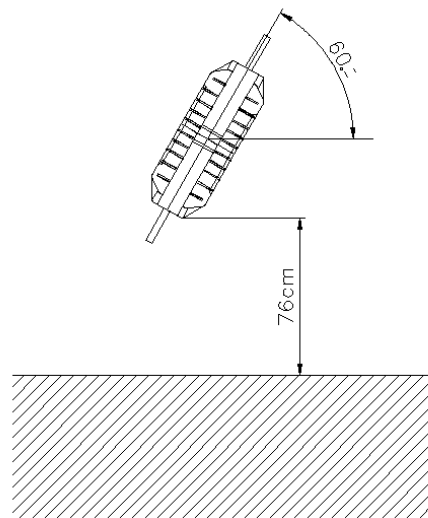

□ Environmental Cycling Test

Samples are placed in an environmental test chamber.

Samples shall be supported in racks during testing in such a way that they are thermally isolated. There shall be free circulation of air both between specimens and between the specimens and the chamber surfaces.

They shall be subjected to 20 cycles defined as follows:

50 minute 20 to -30 °C, 120 minute -30 °C, 90 minute -30 to 60 °C

120 minute 60 °C, 40 minute 60 to 20 °C

After testing, samples shall be subjected to the tightness test described in Section 6. Residual loss shall also be measured as per Section 6.

□ **Chemical Resistant Test**

Installed closure shall be pressurized internally to 6 psi.

One closure assembly shall be immersed in each of the four test fluids for a minimum of 120 hours. After the test period, the splice closures shall be removed from the test fluid and allowed to dry for a minimum of 24 hours at the ambient room temperature.

After testing, samples shall be subjected to the tightness test described in Section 6.

The closure and components shall be inspected for visible corrosion.

□ **Water Immersion Test**

The complete closure assembly shall be subjected to water head in a water tank, or pressure vessel with a hydrostatic head equivalent to 1.5m of water at the ambient room temperature, for 20 days.

After the 20-day period the closure shall be opened and examined for fluorescent contamination.

□ **Dielectric Test**

Measure the thickness of the thinnest part of the closure. Prepare a specimen with the corresponding thickness and apply 10kV DC power for 1 minute. There shall be no damage on the specimen

□ **UV Resistance Test**

Measure and record the tensile strength of 5 test bars per ASTM D 638 using a crosshead speed of 50mm/min.

Using the xenon lamp of wavelength between 300 and 700nm, expose the 5 test bars to UV radiation of $390\text{w/m}^2 \pm 10\%$ for 500 hours

Repeat the tensile strength measurements on the exposed test bars.

■ **Kit Contents**



NO	Descriptions	Quantity
1	Housing	1 Pair
2	Side Gasket	1
3	End Gasket	2 (Φ8), 10 (Φ3)
4	Splice Tray	2
5	Cable Bracket	2 (Φ8), 10 (Φ3)

6	Tension Bracket	2 (Φ8),
7	Bracket Bolt	8
8	Splice Tray Bolt	1
9	Splice Tray Fixture	1
10	Housing Bolt	6
11	Clip (Φ3)	10
12	Clamp (Φ3)	10
13	Cover (Φ3)	2 (In / Out)
14	Cable Ties	24
15	Protection tube	6
16	Support Bracket	2
17	Support Bracket Bolt	4
18	Installation Manual	1

- **Dimension Specification**

- **RN – Closure**

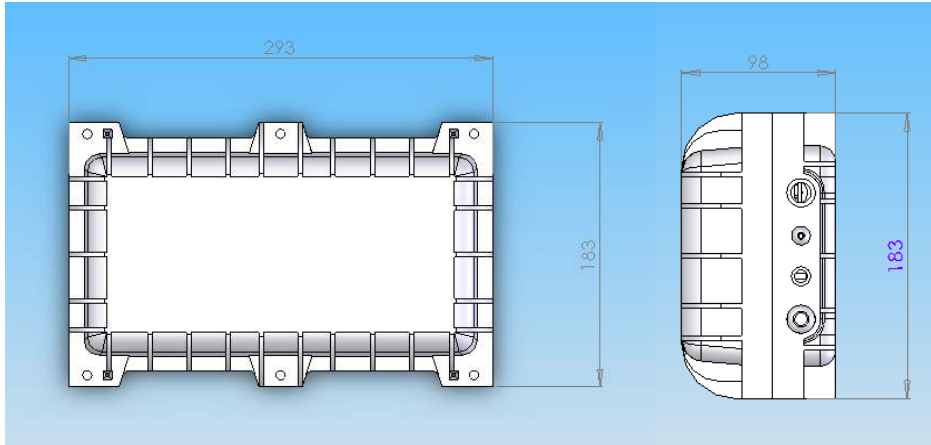

1. Dimensions (mm): 293(W)×183(D)×98(H)
2. Capacity : 12 Fibers (Max. 24)
3. Up to 2 splice trays can be enclosed.
4. Weight: 1.5 Kg

- **OST-B-1**

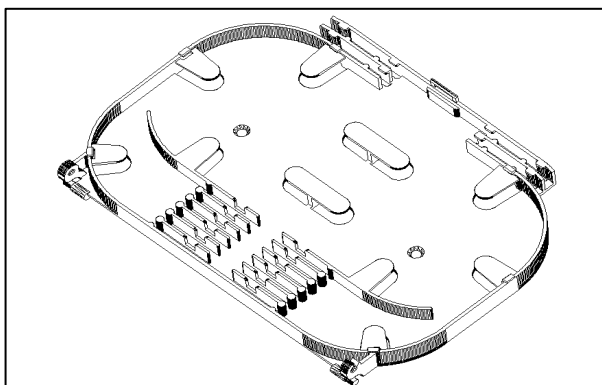

1. Dimensions (mm): 168(l)×119(w)×9(h)
2. Capacity: Heat shrinkable tube: 12 Fibers.

Mechanical splice protector: 6 Fibers.

Ribbon: 48 Fibers/tray

2F TaeKwng Industrial Building, 191-1 Anyand-dong, Manan-gu, Anyang city Kyung-gi, Korea 430-017

Tel. +82 (0)31 464 3777 Fax. +82 (0)31 464 3797

www.networkcable.co.kr info@networkcable.co.kr

3. It can be installed heat Shrinkable tube, mechanical splice protector and ribbon splice protector without other components